

Life-Line™ Capacitor Kit

The Life-Line Capacitor Kit is the all in one replacement kit for your single and dual run capacitor needs. In addition to many single capacitor ratings, this kit has been designed to cover 48 of the most common dual ratings in both in 370VAC and 440VAC applications.

Included in this kit is the following:

- 6 Best in Class Motor Run Capacitors
- 2 Life-Line “Spider” Devices
- 1 Capacitor Mounting Hardware Kit
- 1 Device Mounting Hardware Kit
- 1 Robust Carrying Case

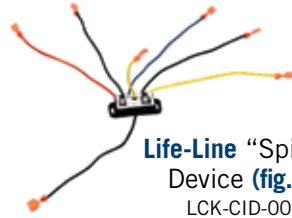

Life-Line “Spider” Device (fig. A)
LCK-CID-001

Life-Line Kit Featuring Genteq Capacitors (fig. B)

Note: Also available with PROLINE capacitors (see table 4 on page 16)

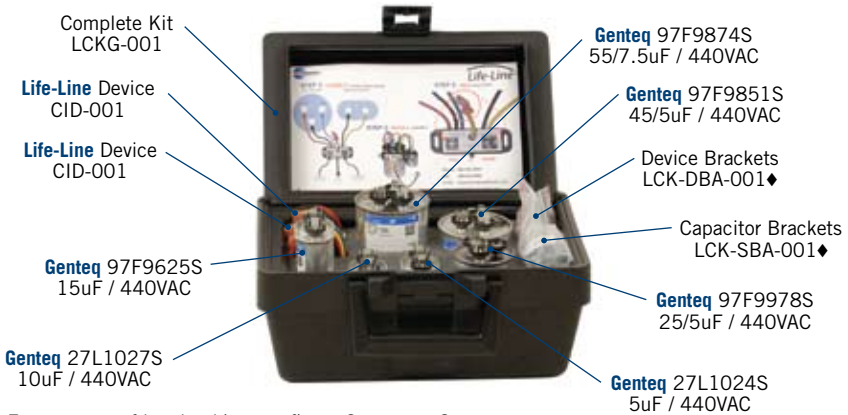

Complete Kit
LCKG-001

Life-Line Device
CID-001

Life-Line Device
CID-001

Genteq 97F9625S
15uF / 440VAC

Genteq 27L1027S
10uF / 440VAC

Genteq 97F9874S
55/7.5uF / 440VAC

Genteq 97F9851S
45/5uF / 440VAC

Device Brackets
LCK-DBA-001♦

Capacitor Brackets
LCK-SBA-001♦

Genteq 97F9978S
25/5uF / 440VAC

Genteq 27L1024S
5uF / 440VAC

♦ For contents of bracket kits, see figure G on page 6.

For direct replacements, please refer to tables 3 and 4 on page 16. You can obtain direct replacements from your local distributor.

Everything needed to select, wire, and mount the replacement capacitor(s) is included in this kit.

This kit saves time and money by having exactly what you need on the job and the ability to only use and replace only what you need.

The UL approved Life-Line Device (patent pending) gives you the ability to turn six capacitors into 48 duals with no guess work. With a simple wiring diagram you will have the system up and running in no time with the safe and reliable installation of multiple capacitors using the technology of parallel capacitors.

Selection Table

In the capacitor selection table below (table 1), simply match the failed run capacitor to the replacement capacitors in the kit. If one replacement capacitor will not directly replace the failed capacitor, the add on capacitor section will show you how to select the correct combination of capacitors. The ratings listed on this chart are in microfarads (mf). Always replace a failed capacitor with the exact microfarad rating. All of these capacitors are rated at 440VAC. They will properly replace any 370VAC or 440VAC capacitor.

Figure C on page 4 shows the mounting and wiring diagrams including how to wire the Life-Line Device if needed.

CAPACITOR SELECTION TABLE (table 1)

Failed Capacitor (mf)		=	Main Replacement Capacitor (mf)		+	Life-Line Device	+	Add on Replacement Capacitor (mf)	
HERM	FAN		HERM	FAN				Add to HERM	Add to FAN
	5		5						
	10		10						
	15		15						
25	5		25	5					
25	10		25	5					5
25	15		25	5					10
25	20		25	5					15
30	5		25	5		Life-Line Device CID-001		5	
35	5		25	5				10	
40	5		25	5				15	
45	5		45	5					
45	10		45	5					5
45	15		45	5		Life-Line Device CID-001			10
45	20		45	5					15
50	5		45	5				5	
55	5		45	5				10	
55	7.5		55	7.5					
55	12.5		55	7.5					5
55	17.5		55	7.5					10
55	22.5		55	7.5					15
60	5		45	5		Life-Line Device CID-001		15	
60	7.5		55	7.5				5	
65	7.5		55	7.5				10	
70	7.5		55	7.5				15	

Bold Font Denotes direct replacement capacitors provided with kit.

Std. Font Denotes requirement of additional capacitor and device.

Installation Guide

WIRING

If a single capacitor is used, then wire according to the HVAC system's schematics.

If an add on capacitor is needed, follow the directions below using the schematic **(as shown in fig. C)**.

(fig. C)

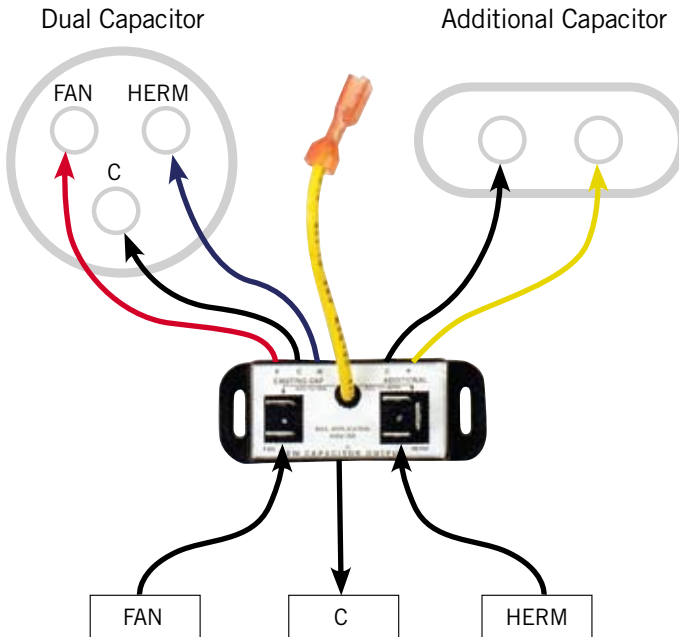

WIRING THE LIFE-LINE DEVICE TO THE CAPACITORS

Step 1: Connect hermetic (H), fan (F) and common (C) wires from the device to their respective terminals on the dual run capacitor **(fig. C)**.

Step 2: Connect the (C) and (+) wires to either of the terminals on the additional capacitor **(fig. C)**.

WIRING (CONTINUED)

ADDING CAPACITANCE TO THE FAN SECTION

Step 3a: If additional capacitance is required for the fan motor (FAN), then connect yellow wire to fan terminal (2 Blade Terminal) on Life-Line Device (as seen in fig. D).

(fig. D)

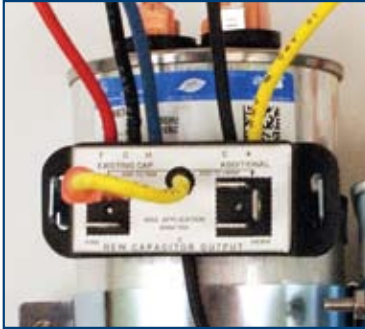

ADDING CAPACITANCE TO THE HERM SECTION

Step 3b: If additional capacitance is required for the compressor motor (HERM), then connect yellow wire to HERM terminal (3 Blade Terminal) on Life-Line Device (as seen in fig. E).

(fig. E)

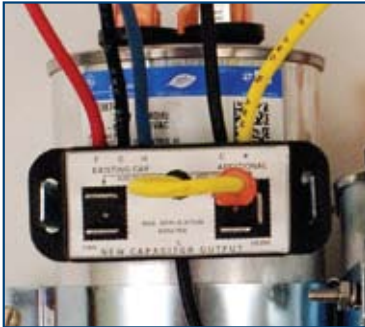

CONNECTING LIFE-LINE SOLUTIONS TO THE HVAC SYSTEM

Step 4: Connect the capacitor (Start Winding) wires from the fan motor and compressor to the FAN (Fan Motor) and HERM (Compressor) taps on the Life-Line Device.

Step 5: Connect the (C) wire from the Life-Line Device to the appropriate line voltage according to the HVAC systems schematics.

NOTE: If a start device is used on the compressor, then connect per manufacturer specifications to the dual run capacitor.

MOUNTING THE CAPACITOR(S)

Once the capacitor(s) have been selected from table 1 on page 3 and wiring has been completed as illustrated in figure C on page 4, it will be time to mount the capacitors into the system.

If one capacitor will directly replace the failed capacitor, then mount using the supplied brackets or existing mounting hardware.

If a combination of capacitors is required, then refer to figures H thru L on page 7.



(fig. F)

NOTE: Depending on how much room is available in the HVAC system, it may be easier to bolt the single or larger capacitor bracket to the system first. **When mounting the single or larger capacitor bracket to the HVAC system, it is required to use both #6 x 1/2" Phillips Pan Head Self Tapping Screws to keep the capacitor(s) from rotating due to vibration.**

Also, a quantity of (4) #6 x 1/2" Phillips Pan Head Self Tapping Screws are supplied in the Capacitor Mounting Hardware Kit for easy mounting of bracket(s) and/or device on sheet metal surfaces.

Brackets and Screws Available in the Kit

Multiple sizes are provided for each different size capacitor supplied.

Life-Line Mounting Hardware Kits (fig. G)

Capacitor Mounting Hardware Kit
(LCK-SBA-001)

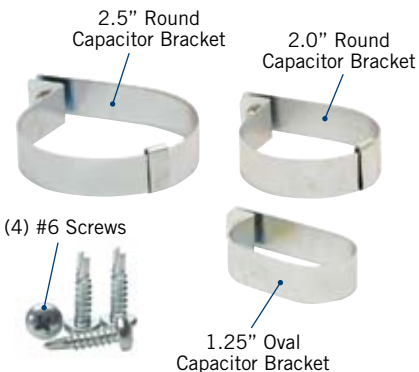

Device Mounting Hardware Kit
(LCK-DBA-001)

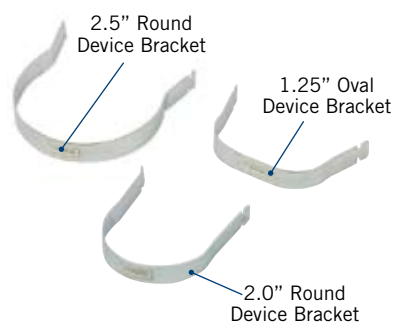

MOUNTING LIFE-LINE SOLUTIONS

When mounting a combination of capacitors, select the brackets that fit the selected capacitors and determine from the space available in the HVAC system how to configure the mounts including the Life-Line Device.

The add-on capacitor can be rotated around the circumference of the dual capacitor as needed to fit into the HVAC system (fig. H).

The Life-Line Device (LLD) can be mounted on either capacitor as needed to fit the space allowed (fig. I). Place the LLD bracket on the capacitor desired, above the capacitor bracket as shown below (fig. J).



(fig. H)



(fig. I)



(fig. J)

Place the LLD on the device bracket and bend the device bracket ends to hold the device in place (fig. K or fig. L) using needle nose pliers.



(fig. K1)



(fig. K2)

Mounted
to
Main
Capacitor



(fig. L1)



(fig. L2)

Mounted
to
Additional
Capacitor

MOUNTING LIFE-LINE SOLUTIONS (CONTINUED)
OPTION 1A – INDIVIDUALLY MOUNTING COMPONENTS

BEFORE
(fig. M)

Failed
Capacitor



AFTER

Dual Rated
Capacitor

Life-Line
'Spider'
Device

Additional
Capacitor



MOUNTING LIFE-LINE SOLUTIONS (CONTINUED)
OPTION 1B – INDIVIDUALLY MOUNTING COMPONENTS

BEFORE
(fig. N)

Failed
Capacitor



AFTER

Additional
Capacitor

Dual Rated
Capacitor

Life-Line
'Spider'
Device



MOUNTING LIFE-LINE SOLUTIONS (CONTINUED)

OPTION 2 – SINGLE STACKED MOUNTING

BEFORE
(fig. 0)

Failed Capacitor



AFTER

Life-Line 'Spider' Device

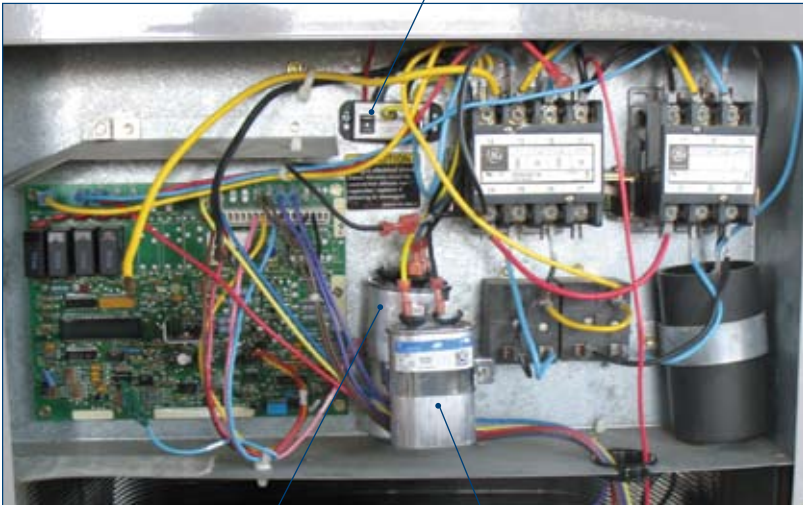

Dual Rated
Capacitor

Additional
Capacitor

MOUNTING LIFE-LINE SOLUTIONS (CONTINUED)
OPTION 3 – DOUBLE STACKED MOUNTING

BEFORE
(fig. P)

Failed
Capacitor



AFTER

Dual Rated
Capacitor

Additional
Capacitor

Life-Line
'Spider'
Device



FINAL INSTALLATION NOTES

Before energizing the HVAC system, always confirm all wiring with the system's schematic and the diagrams provided in this manual. Also confirm that all connections, even the ones not affected, are clean and secure.

After replacing capacitors, always confirm the system operation – including confirmation that voltage and amperage readings fall within the manufacturer's specification on the data plate.

Capacitor Diagnosis Support

If a run capacitor is suspect of being weak or failed, there are different means of diagnosis. The information provided here is for RUN capacitors only.

OHMS TEST

The ohms test will only determine whether the capacitor can charge and discharge – basically telling you that the capacitor acts like a capacitor. This test will NOT determine actual capacitance or capability.

Using an ohm meter set to the highest scale, connect the leads of the ohm meter across the terminals of the capacitor. On dual run capacitors, check (C) to (FAN) or (C) to (HERM) as two separate checks. Leave the leads connected to the capacitor for a couple of seconds. Then simply reverse the meter leads on the two terminals being checked. A good capacitor will cause the ohm meter to read from Infinity to zero and back to Infinity. If there is no movement on the meter, reverse the meter leads again.

If the meter only reads zero, the capacitor is shorted and should be replaced.

If the meter only reads Infinity, the capacitor is open and should be replaced.

Capacitor Diagnosis Support (CONTINUED)

CAPACITANCE TEST

This test will determine the actual capacitance and is the best test to determine whether the capacitor is good, weak or failed. Any single or multi-purpose tool that can provide an analog or digital readout of microfarads (mf) is suitable for this test. However, it should be understood that these tools may typically read from 1-5% higher than the actual capacitance as measured by the manufacturer of the capacitor.

Using a capacitance meter, set to the appropriate scale. If applicable, connect the leads of the meter across the terminals of the capacitor. On dual run capacitors, check (C) to (FAN) or (C) to (HERM) as two separate checks. Wait a few seconds for the reading on the meter.

Most capacitor manufacturers and HVAC OEMs specify $\pm 6\%$ tolerance on microfarads (mf) of the capacitor. If the reading falls outside of this range and fails to meet the OEM designed operating performance, then it should be replaced.

Why Do Capacitors Fail?

Q: Why are there so many infant capacitor failures?

- A:
1. Substandard materials
 2. Poor capacitor design
 3. Improper & inadequate process control

Q: What causes capacitor degradation?

- A:
1. Excessive temperatures to the capacitor designs
 2. Voltages excessive to the design of the capacitor

Q: What are the signs of a failing capacitor?

- A:
1. Loss of capacitance
 2. Increase in dissipation factor (similar to ESR)

Q: Why should a capacitor be replaced?

- A: PSC Motors are designed to run at an optimal load point. This optimal load point is determined by utilizing a specific run capacitor value (mf). Degradation in capacitance translates into deteriorated motor performance and less than optimal system performance.

Deteriorated motor performance can cause the following:

- Temperature rise
- Bearing wear
- Insulation breakdown
- Increased noise
- Increased energy consumption
- Improper cycling
- Stress on other components

Q: After how much deterioration should a capacitor be replaced?

- A: Most OEM's mandate a tolerance of 6% on capacitance. For a reference table on Capacitor Ratings and Meter variation, please see table 2 on page 15.

Capacitance Variation on Common Metering Devices (table 2)

Q: After how much deterioration should a capacitor be replaced?

A: Most OEM's mandate a tolerance of 6% on capacitance

Capacitance Meter Variation: At What Value Should I Replace a Capacitor?

Cap Rating (mf)	Actual Capacitance (mf)	Meter A (mf)	Meter B (mf)	Meter B Delta (mf) vs. Meter A	Meter B Delta % (mf) vs. Meter A
3	2.986	2.990	3.200	0.210	7.02%
4	3.980	3.990	4.300	0.310	7.77%
5	4.988	4.990	5.400	0.410	8.22%
7.5	7.230	7.240	7.800	0.560	7.73%
10	9.987	9.990	10.700	0.710	7.11%
12.5	12.471	12.500	13.300	0.800	6.40%
15	15.176	15.200	16.100	0.900	5.92%
20	19.545	19.600	20.600	1.000	5.10%
25	24.698	24.700	25.900	1.200	4.86%
30	29.706	29.700	31.000	1.300	4.38%
35	34.890	34.900	36.200	1.300	3.72%
40	40.250	40.300	41.600	1.300	3.23%
45	45.620	45.700	47.000	1.300	2.84%
50	49.400	49.400	50.800	1.400	2.83%
55	54.500	54.500	55.900	1.400	2.57%

Cap Rating (mf)	Recommended Replacement @ Rating (mf) - 6%	Meter B Margin of Error	Replacement Value Using Meter B
3	2.8	7.02%	3.0
4	3.8	7.77%	4.1
5	4.7	8.22%	5.1
7.5	7.1	7.73%	7.6
10	9.4	7.11%	10.1
12.5	11.8	6.40%	12.5
15	14.1	5.92%	14.9
20	18.8	5.10%	19.8
25	23.5	4.86%	24.6
30	28.2	4.38%	29.4
35	32.9	3.72%	34.1
40	37.6	3.23%	38.8
45	42.3	2.84%	43.5
50	47.0	2.83%	48.3
55	51.7	2.57%	53.0

Meter B margin of error %

Meter B suggested replacement value based on Meter B margin %.

The table above is a representation of only a small sample of meters with a capacitance function. **One way to get a quick estimate of your meters accuracy is to measure the capacitance of a new capacitor. If the metered rating is significantly above the rating on the capacitor you may want to take that into consideration on future readings.**

Replacement Parts List

Life-Line Capacitor Kit Featuring Genteq Capacitors (table 3)

Part Number	Description
LCKG-001	Complete Kit Featuring Genteq Capacitors

Part Number	mf Rating	Voltage	Case Dia	Case Hgt	Qty in Kit
27L1024S	5 mf	440 VAC	1.25" Oval	2.12"	1 Cap
27L1027S	10 mf	440 VAC	1.25" Oval	2.88"	1 Cap
97F9625S	15 mf	440 VAC	1.25" Oval	4.75"	1 Cap
97F9978S	25/5 mf	440 VAC	2.00" Round	3.88"	1 Cap
97F9851S	45/5 mf	440 VAC	2.50" Round	3.88"	1 Cap
97F9874S	55/7.5 mf	440 VAC	2.50" Round	4.75"	1 Cap

Part Number	Description	Qty in Kit
LCK-SBA-001	Capacitor Mounting Hardware Kit❖	1 Kit
LCK-DBA-001	Device Mounting Hardware Kit❖	1 Kit
CID-001	Life-Line "Spider" Device⊕	2 Devices

Life-Line Capacitor Kit Featuring PROLINE Capacitors (table 4)

Part Number	Description
LCKP-001	Complete Kit Featuring Proline Capacitors

Part Number	mf Rating	Voltage	Case Dia	Case Hgt	Qty in Kit
PB050E000A440BAS	5 mf	440 VAC	1.25" Oval	2.12"	1 Cap
PB100E000A440CAS	10 mf	440 VAC	1.25" Oval	2.88"	1 Cap
PB150E000A440EAS	15 mf	440 VAC	1.25" Oval	4.75"	1 Cap
PB250Z050S440DAS	25/5 mf	440 VAC	2.00" Round	3.88"	1 Cap
PB450Z050T440DAS	45/5 mf	440 VAC	2.50" Round	3.88"	1 Cap
PB550Z075T440EAS	55/7.5 mf	440 VAC	2.50" Round	4.75"	1 Cap

Part Number	Description	Qty in Kit
LCK-SBA-001	Capacitor Mounting Hardware Kit❖	1 Kit
LCK-DBA-001	Device Mounting Hardware Kit❖	1 Kit
CID-001	Life-Line "Spider" Device⊕	2 Devices

- ❖ The Capacitor Mounting Hardware Kit (LCK-SBA-001) includes:
 (1) 1.25" Oval Capacitor Bracket, (1) 2.00" Round Capacitor Bracket, (1) 2.50" Round Capacitor Bracket, and (4) #6 x 1/2" Phillips Pan Head Self Tapping Screws
- ❖ The Device Mounting Hardware Kit (LCK-DBA-001) includes:
 (1) 1.25" Oval Device Bracket, (1) 2.00" Round Device Bracket, and (1) 2.50" Round Device Bracket
- ⊕ The Complete Life-Line Capacitor Kit comes with 2 Life-Line "Spider" Devices (CID-001) with replenishment quantity in 4-packs sold separately (LCK-CID-001).